

Section 1: Introduction

Thank you for purchasing the Vanner Max SP00143 Battery Charger. We are confident that you will be satisfied with this charger's performance and its many features. With proper installation and care, you can look forward to years of service from this high performance product.

This document will describe the operation, technical specifications, and installation procedures of this product. If you require additional information please contact your dealer, or contact us directly at the location shown on this inside cover of this manual.

Section 2: General Information

2A) Introduction and Checkout

The Vanner Max SP00143 Battery Charger is a high performance three-stage battery charger that has the ability to precisely charge 24VDC battery banks. The Max incorporates advanced battery charging technology, correctly charging batteries automatically at rated ampere output rather than tapering off like some other battery chargers.

The Max's unique three-stage charging design provides precise battery charging automatically. When plugged in, the Max enters BULK Stage and will charge at full ampere outputs for at least 20 minutes, or until the battery cells equalize at 28.6 VDC. The charger then automatically switches to ABSORPTION stage, which maintains 28.6 VDC until the battery is fully charged. The final FLOAT Stage will stabilize battery voltage at 26.6 VDC until the charger is unplugged or the charger's current limit has been reached. This three-stage design keeps batteries in top condition and minimizes battery failure, resulting in maximum battery life.

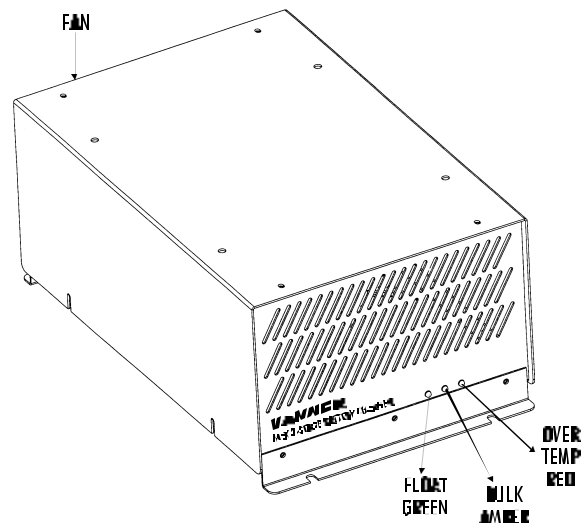

2B) Specifications

Model No.	SP00143
Input:	15A at 120VAC \pm 10%, 60Hz
Output:	41A at 24VDC Nominal
DC Current Draw:	30 milliamperes (with no AC voltage applied)
Bulk Voltage:	28.6VDC Nominal
Float Voltage:	26.6VDC Nominal
Ambient Temperature:	-40 to +105°F (-40 to +40°C)
Cooling:	Forced Air, 100 CFM, 24VDC Fan with front to rear air flow
Chassis:	Steel with durable painted finish
Weight:	35 lbs
Dimensions:	9.85" W x 6.70" H x 15.75" D

2C) Standard Features

- Fully Automatic Operation with Three-stage Battery Charging (Bulk, Absorption, and Float Stage Charging)
- Two Year Warranty
- Over Current Protection of AC Input and DC Output to Protect Both the Charger and the Batteries
- Durable Steel Enclosure
- 3 Status LEDs Describe the Status of the Charger (Green/Amber), or Over Temperature/Shutdown (Red) Condition

SECTION 3: Installation and Checkout**NOTE**

Charger should not be installed in same compartment as batteries.

3A) Selection of Battery Charger Location

- Charger should be located close to battery (but not in the same compartment) for optimum performance (within 3ft.)
- Charger should be protected from weather. Install charger in compartments that provide protection from direct water spray, dirt, or toxic vapor.
- Mounting compartment should be well-ventilated and allow adequate air circulation for charger cooling (2" clearance around entire charger recommended).
- Do not store flammable items near charger.

**WARNING**

Safety goggles should be worn when working with or near batteries.

3B) Charger Mounting

- Install Charger in horizontal position, (mounting brackets are attached to the unit). This unit requires airflow under chassis for proper cooling.

3C) Routing and Connecting Battery Charger DC Output Cables

This Charger is designed for 24 VDC applications only. If connected to non-specified voltages, damage will result.

1. Connect the Max Charger's RED cable to the battery's positive (+) terminal and the BLACK cable to the Battery's negative (-) terminal.
2. Battery cable connections must be clean and secure to minimize electrical resistance for optimum performance.
3. Route and secure charger DC cables away from Hot, Sharp, or Hard surfaces and components.
4. Ground the charger case properly. The unit is not grounded through the negative DC cable.

**WARNING**

Battery connections must pass a minimum of 50 amps.

3D) Battery Charger Parts List**Vanner Part Numbers**

Circuit Breaker:	07485	Cooling Fan:	07668
PCB Assembly:	D07586	Relay:	06606
Capacitor:	05083	Rectifiers:	04898

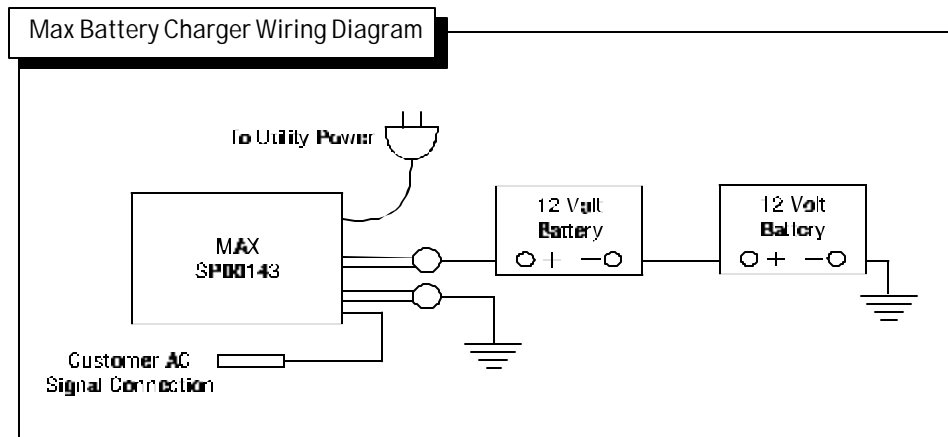

SECTION 4: Battery Charger Operating Procedure

4A) Charger Setup

1. The GREEN light should be blinking whenever the 120 VAC power is *not* plugged in and the battery is connected to the Max Battery Charger.
2. To start the charger, plug the AC line cord into a 15 Amp 120 Volt 60Hz power source.
3. The Charger will remain on until unplugged from the power source.
2. To start the charger, plug the AC line cord into a 15 Amp 120Volt 60Hz power source.

4B) Charging Stages

1. When plugged in to a 120VAC shore power the charger automatically goes into BULK mode (if the batteries require it) and the Amber LED lights up. The Charger stays in BULK mode, which will maintain 28.6 VDC until the charging current drops below 75% of full rated load.
2. When the charging current drops below 75% of the full rated load of the charger, the charger will switch to the ABSORPTION stage for 20 minutes by stabilizing the battery voltage at 28.6 VDC.
3. After the ABSORPTION stage the charger enters the final or FLOAT stage. The Amber BULK LED will turn Off and the Green FLOAT LED will turn On. The Max charger will hold the battery voltage at 28.6 VDC until the charger is unplugged or the battery charger current limit of 41 Amps is reached through DC loads such as accessories, lights, etc. which will then start the BULK stage again.

Vanner Max Three-Stage Battery Charging Graph

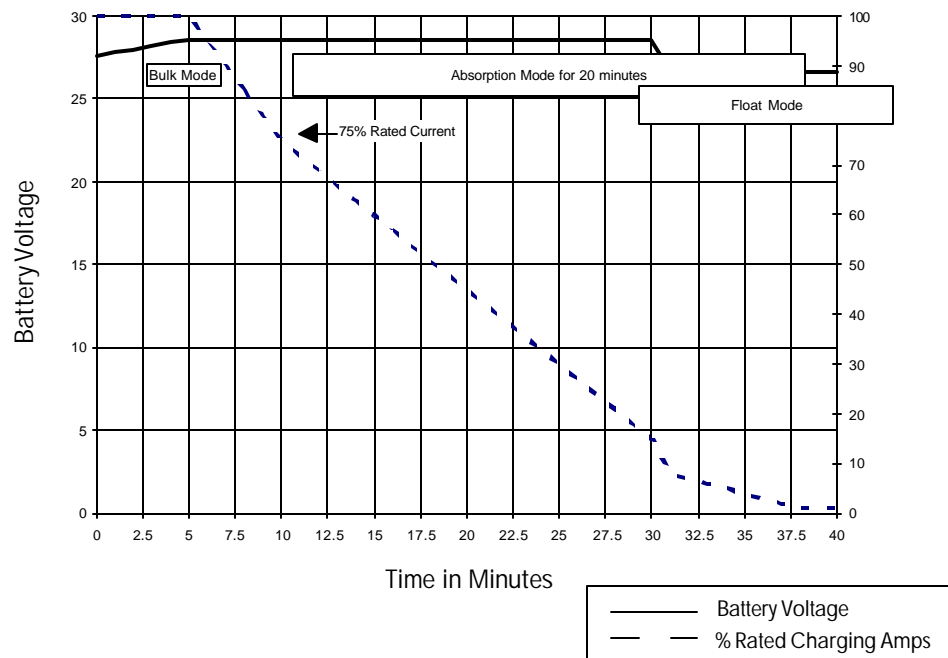

Max Charger SP00143 LED Status Indicators

O V E R T E M P	L I G H T A C T I O N	D E S C R I P T I O N
	Solid Red	The Charger is Off due to over temperature. Shutdown may be caused by high ambient temperature or restricted cooling air flow to charger. Shut down sensor will auto reset when the unit has cooled.
B U L K	L I G H T A C T I O N	D E S C R I P T I O N
	Solid Yellow	Charger is On. Battery is low and being charged at full current output. Current output will remain at a constant level until battery voltage reaches bulk voltage setpoint. Then, charger remains in Absorption stage (constant voltage-reducing current) for a timed period before reducing to float stage.
F L O A T	L I G H T A C T I O N	D E S C R I P T I O N
	Solid Green	Charger is On. Battery is close to full charge. Charger output voltage is reduced to a preset maintenance level.
	Blinking Green	Charger is Off. Either the AC or DC is disconnected from the charger. Usually the AC input power is off. Sometimes this condition will occur when the charger has good 120 VAC input but the frequency is not 60Hz.



OWNER'S MANUAL

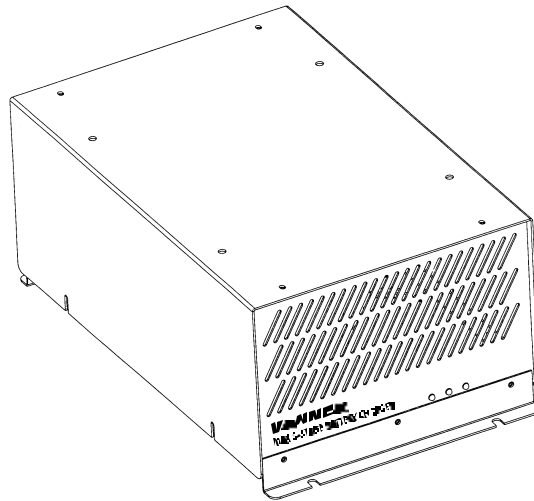

Max Battery Charger Model SP00143

OM/D97598-A

VANNER POWER GROUP

Corporate Office:

4282 Reynolds Drive • Hilliard, Ohio 43026
Tel (614) 771-2718 • Fax (614) 771-4904

1-800-AC POWER

MAX SP00143 BATTERY CHARGER—OWNERS MANUAL ©Copyright 1997, Vanner, Inc.

OMD97598-A

Table of Contents

Section 1	Introduction	1
Section 2	General Information	
	Section 2A Introduction and Checkout	1
	Section 2B Specifications	2
	Section 2C Standard Features	2
Section 3	Installation and Checkout	
	Section 3A Selection of Battery Charger Location	2
	Section 3B Charger Mounting	3
	Section 3C Routing and Connecting Battery Charger DC Output Cables	
	Section 3D Battery Charger Parts List	3
Section 4	Battery Charger Operating Procedure	
	Section 4A Charger Setup	4
	Section 4B Charging Stages	4
Section 5	Warranty	6

List of Figures

Section 2	General Information	
	Section 2A Vanner Max Illustration	1
Section 3	Installation and Checkout	
	Section 3D Max Battery Charger Wiring Diagram	3
Section 4	Battery Charger Operating Procedure	
	Section 4B Vanner Max Three-Stage Battery Charging Graph	4

Icon Legend



NOTE

Important Information



WARNING

Failure to observe Warning could cause damage to equipment or harm personnel

Vanner Power Group

4282 Reynolds Drive
Hilliard, Ohio 43026
Tel (614) 771-2718
Fax (614) 771-4904

Specifications Subject to Change

© Copyright 1997, Vanner, Inc.

Printed in the U.S.A.

OM/D97598-A — 5/97