

VANN-Bus 90-Series

Converter-Isolator System

With CAN Capable Smart Monitor™

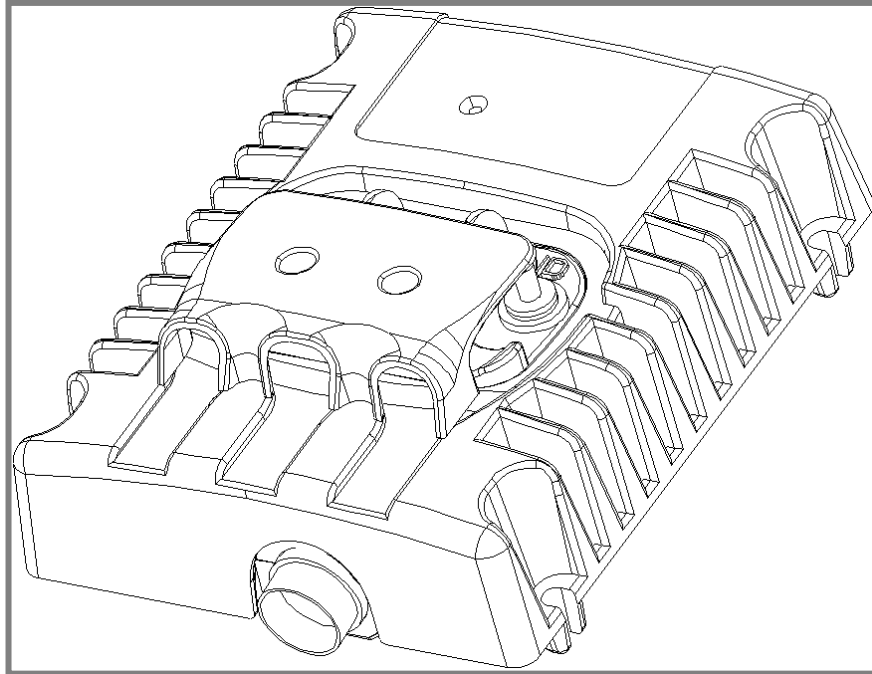

Table of Contents

| | |
|----------------------------------|----|
| Introduction..... | 3 |
| Specifications..... | 4 |
| Theory of Operation..... | 5 |
| Typical Applications..... | 8 |
| Installation Instructions..... | 10 |
| Testing and Troubleshooting..... | 13 |
| CAN Bus Interface..... | 15 |

Introduction

Thank you for purchasing a Vanner *90-60 Converter-Isolator*. We are confident that you will be very pleased with its performance because our 90-Series Converters are designed and manufactured by skilled professionals using the highest standards in workmanship. With minimum maintenance and care, you can be assured of many years of trouble free service.

General Description

The Vanner *VAN-Bus CAN Power Management System* is an efficient and highly reliable method of maintaining isolation between your 24-Volt DC starting system and your 24-Volt DC auxiliary system. In addition to providing regulated 24-Volt power, the system provides charging to the 24-Volt auxiliary battery, when conditions permit, which significantly extends battery life. Ideally suited for vehicle and alternate energy applications, the *VAN-Bus* is designed to save your batteries and the money you would spend replacing them. Users of the Vanner *VAN-Bus* know that it is the most cost effective and dependable solution for 24-Volt systems.

The CAN (Controller Area Network) Capable Smart Monitor is a device designed to monitor and report the status of several critical functions in the vehicle electrical system. This unit provides real-time fault signals over the CAN bus to the vehicle electrical system controller. Fault indications can then be given from the vehicle's electrical system controller. Battery-monitoring algorithms have been incorporated into the 90-60 Series *VAN-Bus*, transmitting real time battery state of charge, state of health, and run time messages over CAN.

A typical system would include a 24-Volt DC-starting system, a 24-Volt DC auxiliary system, and the *90-Series*. The *90-Series* connects to the 24-Volt starting system, 24-Volt auxiliary system and ground terminals of the battery system. When the auxiliary battery requires charging, the *VAN-Bus* ensures that the current is transferred from the starting batteries, when conditions permit, and that the auxiliary batteries can not drain the starting batteries when loads are left on. This isolation between the two 24-Volt systems ensures that the starting batteries will maintain the power required to start the vehicle, and provides a stable 24-Volt supply for operating accessories.

NOTE: The Vanner *VAN-Bus CAN Power Management System* is an extremely reliable device and, when installed according to the instructions, will provide reliable operation for an indefinite period of time. However, if a system abnormality should develop that would cause a *VAN-Bus* malfunction, damage to the battery system could result if 24-Volt loads are present.

Specifications

| 90-Series Converter-Isolator | |
|------------------------------|---|
| Model Number | 90-60CAN |
| Input Voltage 24v | 18 to 32 v |
| Efficiency (Peak) | >97% |
| Max 24v Input Amps | 32 |
| Output Voltage | Programmed via CAN |
| Output Amps (24v) | 0-62 |
| Standby Current | 20 milliamps nominal at 28.4V |
| Smart Monitor | Alarm Low/High Voltage, Imbalance, Under voltage protect override, VAN-Bus fault Battery Monitoring |
| Operating Temp. | -40°C to +75°C (-40°F to 167°F) |
| Storage Temp. | -54°C to +95°C (-65°F to 203°F) |
| Serviceable | Yes |
| Environmental Considerations | Cast aluminum enclosure provides protection against salt, fungus, dust, water, fuel vapors and all fluids associated with commercial and off-highway vehicle operations. IP rated 56. |
| Mounting Location | Mount on a flat surface close to the batteries to allow short cable runs. Location should be protected from battery acid and gases. |
| Weight | 8.8 lbs. |

90-Series CAN Dimensional Specifications

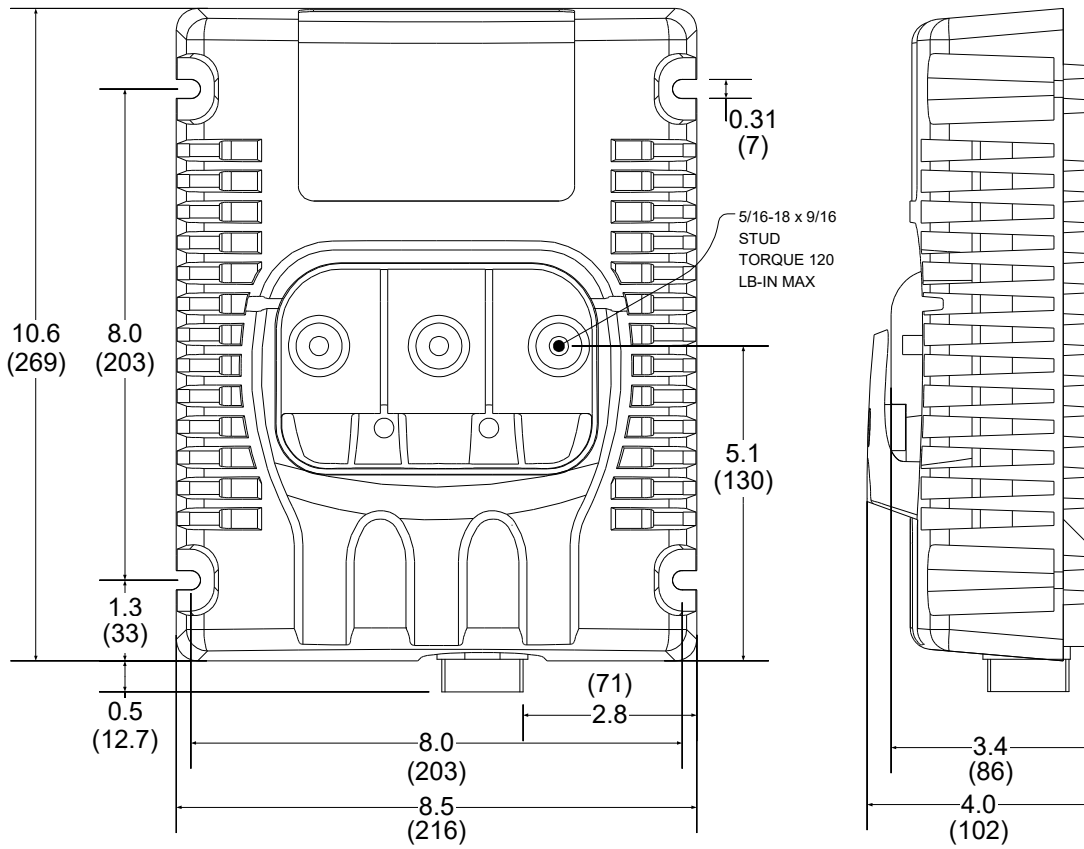

Figure 1 - 90-60 Dimensions

Theory of Operation

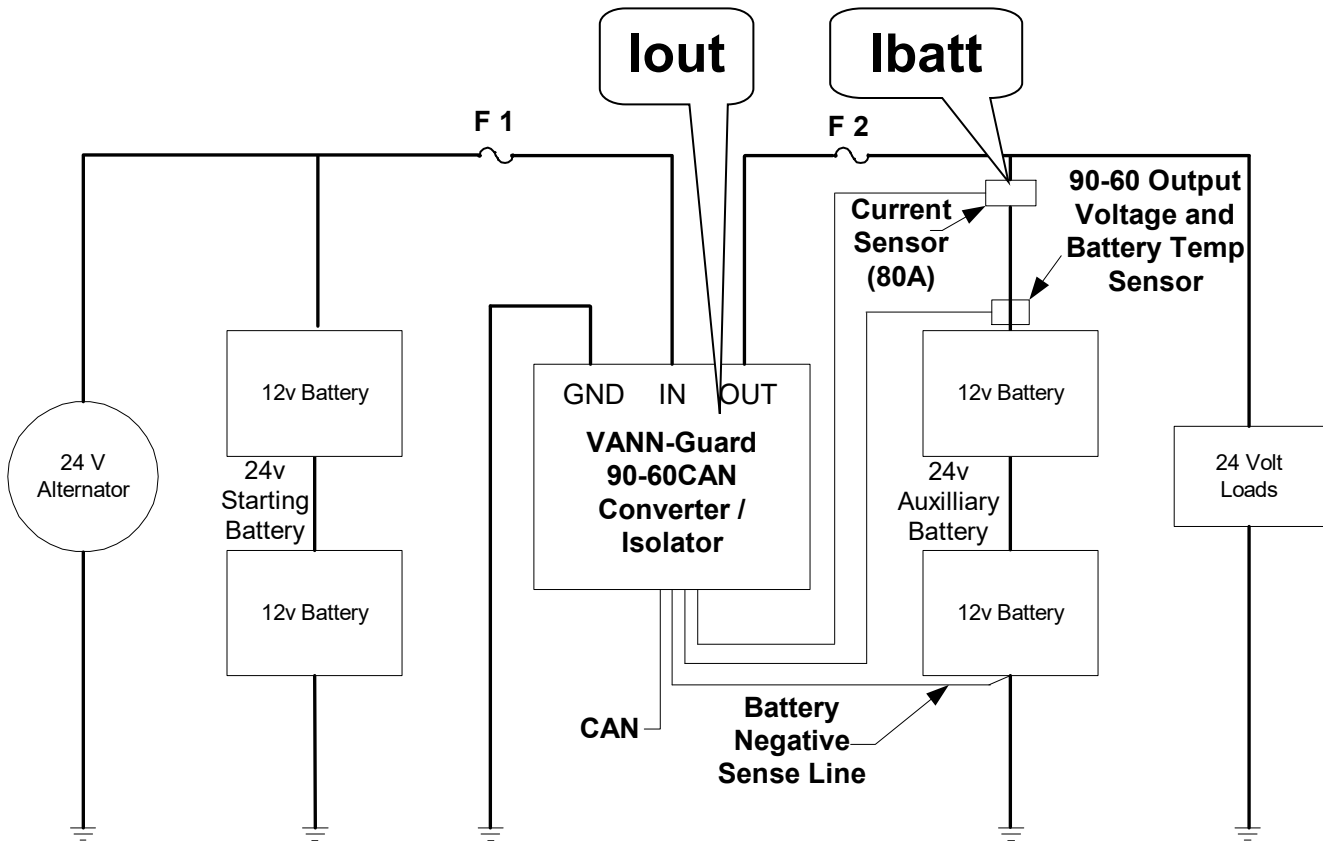

Figure 2 - 90-60 Stand Alone System

The Converter-Isolator is a state of the art device that implements software controlled power management. When the unit has been installed and the system is engaged, the 90-Series will look at the input voltage line to determine if there is sufficient voltage to turn the unit on. If there is not, then the unit does not turn on. If there is then the unit performs a “soft start” cycle that will ramp up the output current to the default setpoint of 60-Amps DC. If at some point during the soft start cycle the output voltage plateaus at a lower value than 20-Volts, then the Output current limits to a lower value than 60-Amps. If the Output Voltage climbs to the default setpoint of 20-Volts, then the unit will continue operation, regulating the output voltage to the default values.

The 90-Series is also capable of being controlled by the CAN Bus. Through CAN communication (J1939 Standard) the unit can have many of its operating parameters adjusted. The adjustments are:

1. Input Voltage Setpoint
2. Output Voltage Setpoint
3. Current Limit Setpoint
4. Battery Type
5. Bulk Charge Voltage
6. Float Charge Voltage
7. Battery Temperature Coefficient

If during normal operations the unit should have an output voltage dip, below 20-Volts, again the unit will limit the current below the 60-Amp Default. If the unit's output voltage rises above 30-Volts then the unit will power off for 10 seconds and perform a restart procedure including the soft start sequence. Furthermore, if the unit experiences an over temperature condition, it will also enter into a current limit (a 10% reduction in the output current capacity) to reduce internal temperatures. If this condition persists, the unit will again reduce current output, until the unit gets out of the internally monitored thermal danger zone. If the temperature continues to rise, the unit will again power off for 10 seconds and attempt a restart. If the temperature remains high, then the unit will NOT operate until the temperature is within the rated operating temperatures.

Converter-Isolator functionality

All functionality described in this section requires that the Monitor Ignition Input (Terminal B) be connected to +24v in order to be active. Please see the above figure for placement of the current and temperature sensors.

A. Switched Sensor Supply Output

This output is used to provide +5v for Vanner VSS Series current sensors and temperature sensor. The +5v output is switched for low power shutdown and sleep mode operation.

B. Ignition (Enable) Input

This input powers the Converter-Isolator. When this pin is taken to +24V the Converter-Isolator becomes active.

C. CAN Shield

This connection is used to make common the shield on the CAN cable. This is required for noise considerations in vehicle electrical systems.

D. CAN Low

This is the connection for the vehicle's public CAN bus. The Smart Monitor will communicate faults to the vehicle's electrical system controller via the CAN bus.

E. CAN High

This is the connection for the vehicle's public CAN bus. The Smart Monitor will communicate faults to the vehicle's electrical system controller via the CAN bus.

F. Not Connected

This pin is not currently used.

G. Not Connected

This pin is not currently used.

H. Sensor Ground

Connect ground for current sensors and Smart Sensors here.

J. Single Current Sensor (+24V) Signal Input

The monitor can record incoming and outgoing battery current on the upper (+24V) battery. The output from the current sensor monitoring the +24v battery line should be connected to this input.

****Note that the arrow on the current sensor should pointed toward the battery if it is connected to the positive terminal of the battery.****

K. Not Connected

This pin is not currently used.

L. Temperature Sensor

The monitor can record the temperate of the batteries. The output from the Vanner temperature sensor should be connected to this input.

M. +24V Battery Input Sense (Starting Batteries)

If this pin is connected directly to the +24V battery positive by a separate line, it will improve the accuracy of the Converter-Isolator input voltage when load current is drawn. See "Remote Sense" below for more information.

N. +24V Battery Output Sense (Auxiliary Batteries)

If this pin is connected directly to the +24V battery positive by a separate line, it will improve the accuracy of the Converter-Isolator balance of the batteries when load current is drawn. See "Remote Sense" section below for more information.

P. Battery Ground Remote Sense

If this pin is connected directly to the battery ground by a separate line, it will improve the accuracy of the Converter-Isolator voltage measurement of the batteries when load current is drawn. See below for more information.

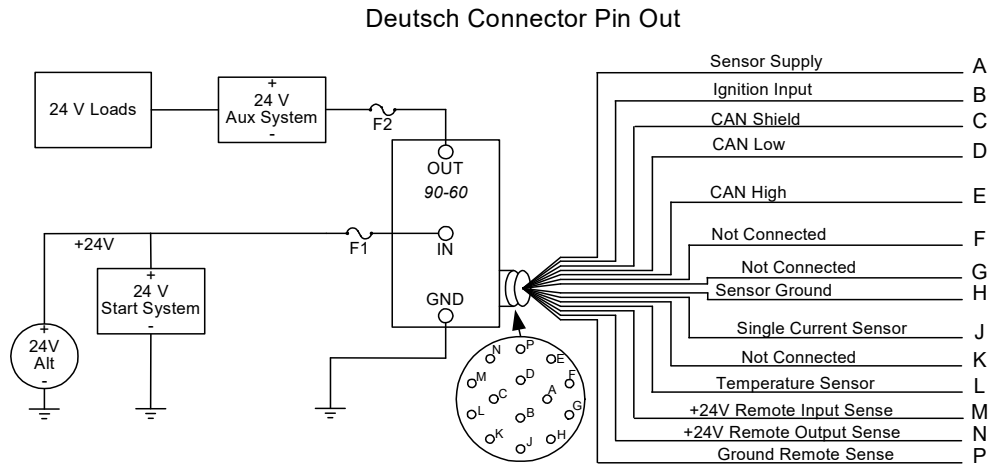

The monitor output from the unit is a through a Deutsch brand connector P/N: HDP20-18-14PN. The mating connector is the Deutsch P/N: HDP26-18-14SN housing with Deutsch P/N: 1062-16-0622 socket contact.

Remote Sense (Terminals M, N, and P)

There are three inputs for this function, +24 Input (starting), +24 Output (auxiliary), and Ground. They are for remote sense of the starting and auxiliary battery voltages. This makes the Conversion function insensitive to wire, fuse and connection voltage drops. All three sense lines must be connected for this function to work properly. It is usual for the battery connections to be brought to a distribution point from where connections are made to the rest of the vehicle. Since the battery charge current is the only current which the battery cables carry for most of the time it is convenient to connect the sense wires to these distribution points. This should not introduce a significant error. In fact, when the system stabilizes and the batteries are charged there will be almost no error. Should the external sense lines be removed, or operating improperly, the Converter will default to internal readings.

The sense wires can be 16 or 18AWG as the input impedance is high, and the wire gauge can be set for mechanical strength requirements. This allows cost savings and freedom of configuration in the Converter power connection wiring, and more freedom in Converter location. The Converter current carrying wire gauge can be the minimum size listed in this manual's wire size table for a given Converter rating, up to four times the distance listed. This sets a maximum voltage drop of 0.4V, which is reasonable from efficiency and fault detection considerations.

Installation Instructions

Do not exceed the specified torque of 120 in-lbs. when connecting cables to the terminal posts (Input, Output, and GND) during installation of all the VAN-Bus Models. Torque values higher than specified may damage the product, reduce performance, and/or create hazardous conditions. Products damaged by improper torque are not covered by the warranty.

Do not connect more than one conductor per terminal post on any Vanner VAN-Bus. Multiple wires and cables may overstress internal components, resulting in poor performance or creating hazardous conditions. Products damaged by the installation of multiple conductors per post are not covered by the warranty.

Fault protection devices MUST be installed between the VAN-Bus and the power source (battery). A fault protection device would be any fuse or circuit breaker properly rated for the maximum DC current obtainable. This advisory is in accordance with SAE, NEC and UL, for mobile power applications. Install per applicable codes or within 18" of the battery. See Wire and Fuse Sizing Chart on page 10 of this manual or contact Vanner at 1-800-227-6937 or pwrsales@vanner.com if assistance is needed in sizing fault protection devices.

Caution: This equipment tends to produce arcs and sparks during installation. To prevent fire or explosion, compartments containing batteries or flammable materials must be properly ventilated. Safety goggles should always be worn when working near batteries

Mounting Location –The VAN-Bus may be mounted in any orientation, on a flat mounting surface suitable to support the VAN-Bus during application. Do not mount in zero-clearance compartment that may result in the VAN-Bus overheating. Locate so that contact by people is unlikely.

Environmental Protection – Your VAN-Bus has been designed to withstand direct exposure to rain and moisture. The VAN-Bus has also been tested for exposure to direct pressure spray, but continual exposure to direct pressure spraying may reduce the VAN-Bus serviceable life. Vanner covers any damage due to water contamination only through the terms of our factory warranty.

Wiring Sequence– The VAN-Bus is internally protected for reverse polarity. The wiring sequence is not an issue with the VAN-Bus products.

Strain Relief – The VAN-Bus has an integral strain relief. The VAN-Bus is designed with wells for the lug to sit into to resist bolt loosening from cable movement, and the strain relief is designed to further inhibit cable movement. The diagram below shows the proper orientation for the attachment of the strain relief and the #10-32 mounting hardware that is supplied.

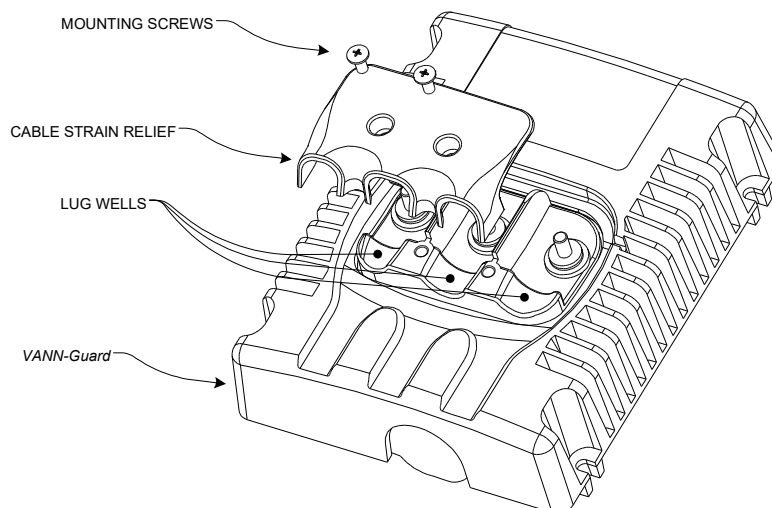

Wire Size and temperature rating

Cables connecting the *VAN-Bus* to the batteries must be sufficiently sized to prevent unwanted voltage drops. These voltage drops (loss) must be less than 0.05 VDC between the *VAN-Bus*'s +24 volt terminal and the battery +24 volt terminal (Battery B positive terminal), less than 0.10 VDC between the *VAN-Bus*'s Input terminal and the battery +24 volt terminal (the jumper between Battery A and Battery B), and less than 0.05 VDC between the *VAN-Bus*'s GND terminal and the battery ground terminal (Battery A negative terminal that is connected to chassis ground). In most installations, the *VAN-Bus*'s terminals are wired directly to the battery terminals (reference fault protection) to prevent voltage loss that could occur in switch contacts, connections, and long wire runs. Since the *VAN-Bus* can be operated in temperatures up to 75°C, use wire rated at least 90°C. See Wire and Fuse Size Chart.

Wire and Fuse Size Chart

| Wire Size AWG | Ring Terminal AMP or UL recognized equal | Max wire length, in feet, between <i>VAN-Bus</i> and battery to keep voltage drop under 0.1 volt. The chart assumes wire carries no other load and wire temperature is below 80°C. |
|---------------|--|--|
| | | 90-60CAN |
| #8 | 33462 | 2.1 |
| #6 | 33466 | 3.2 |
| #4 | 33470 | 5.9 |
| #2 | 322870 | 8.7 |
| #1 | 321867 | 10.9 |
| #1/0 | 321867 | 13.8 |
| #2/0 | 321870 | 17.6 |
| Fuse F1 | | 120 amp |
| Fuse F2 | | 100 amp |

Crimp the ring terminals using **AMP** ROTA-CRIMP 600850 (2/0 - 8ga).

AMP Product Information Center: 800-522-6752

AMP Tooling Assistance Center: 800-722-1111

Note: The wire gages listed are for use without remote sense; see the monitor section for applications using the remote sense capability.

Testing and Troubleshooting

CAUTION

Servicing of electrical systems should only be performed by trained and qualified technical personnel.

Equipment Required

Voltmeter having 0.01 volt resolution. (Fluke Model 87, or higher, Multimeter recommended).

Clamp-on current meter (Fluke Model 36 Clamp-on Meter recommended).

Vanner Repair Service

Vanner offers a quick turn around factory repair service. Send the unit to the address below with a note instructing us to repair it. Include your name, phone number, shipping address (not a P.O. Box Number), and your purchase order number.

Test Procedure for *VAN-Bus* 90-Series CAN Power Management Systems

The VAN-Bus is working properly if:

1. The 24 volt DC loads are being operated continuously and are within the rated capacity of the VAN-Bus and;

Vanner *VAN-Buss* are electronically protected against reverse polarity damage therefore the DC connection sequence is not an issue.

Vanner *VAN-Buss* will not function properly unless all three-battery connections are made. Battery A and Battery B voltages both must be above 8 volts for the unit to turn ON.

Vanner *VAN-Buss* may be used in parallel with other *VAN-Buss* and Vanner Equalizer models.

Please note that the Input, Output and GND stud positions and orientation are different on *VAN-Bus* 90-Series than on other Vanner Equalizers.

**Vanner Incorporated
4282 Reynolds Drive
Hilliard, Ohio 43026**

**1-800-AC POWER
(1-800-227-6937)
Tel: 614-771-2718
Fax: 614-771-4904**

**www.vanner.com
e-mail: pwrsales@vanner.com**

**Part Number D913789-C, 8/15/2022
Printed in U.S.A.**